

# FIELD ASSEMBLED MULTI LEVEL FA-2002-SS

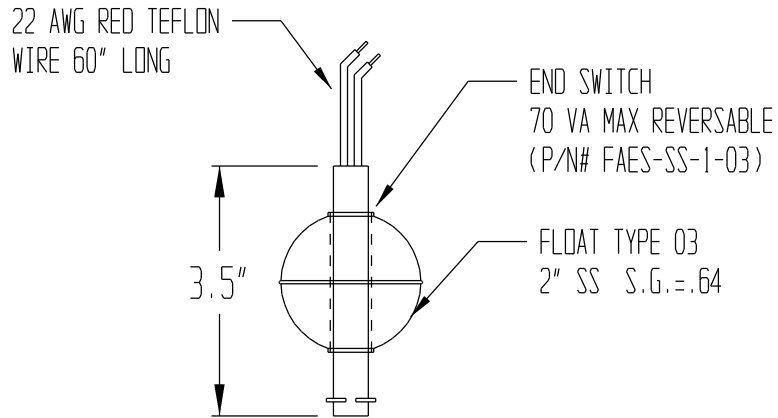
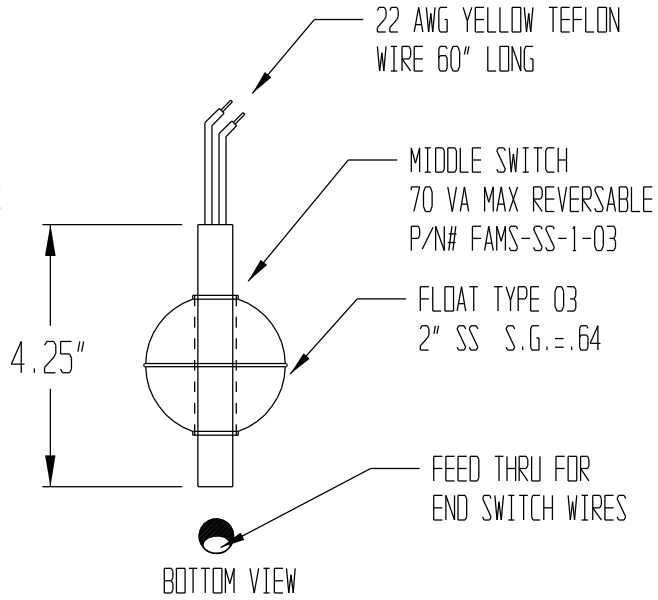
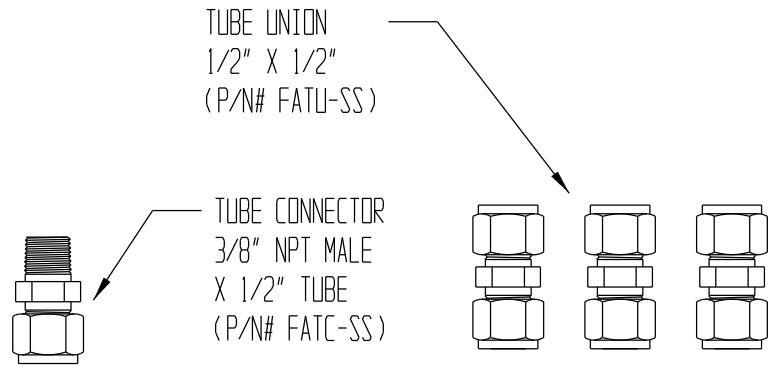
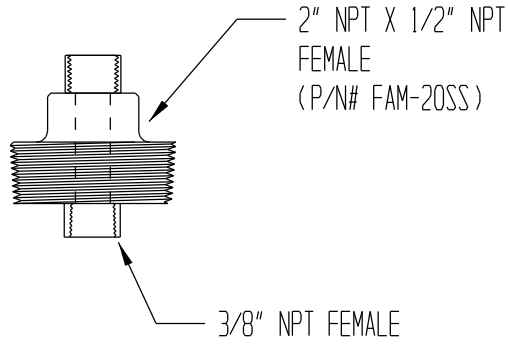

**PLEASE NOTE:**

THIS DRAWING AND SPECIFICATION IS THE PROPERTY OF INNOVATIVE COMPONENTS AND IS TO BE USED SOLELY AS A TECHNICAL REFERENCE BY INNOVATIVE COMPONENTS' CUSTOMERS. ANY REPRODUCTION OR DISTRIBUTION TO THE CONTRARY IS PROHIBITED.

SIGNATURE OF APPROVAL	DATE
PRINT: _____	_____
SIGN: _____	_____

	<b>INNOVATIVE COMPONENTS</b>	
	384 OLD TURNPIKE ROAD, P.O. BOX 294 SOUTHINGTON, CT. 06489	

STANDARD TOLERANCES .000 = ± .010 .00 = ± .050 .0 = ± .100 0 = ± .200 ANGLES ± 5° TEMP ± 5°C	TITLE: <b>FIELD ASSEMBLED MULTI LEVEL</b>	
	MODEL: <b>FA-2002-SS</b>	DRAWN BY: F.J.K
	STOCK: <b>FA-2002-SS</b>	DATE: 05/08/03
	FILENAME: C:\CK7\PR\FA2002SS\1MASTER	SHEET: 1 OF 1
	REV:	SCALE: NONE